



HV Hydraulic S.r.l.

Via dell'Agricoltura, 162

Loc.Castello di Serravalle - 40053 Valsamoggia (BO)

Tel.:+39.051.670.50.11 - Fax:+39.051.670.53.74

E-mail: info@hvhydraulic.com

Installation and operation manual

TWO-STAGE HAND PUMPS FOR DOUBLE-ACTING CYLINDER

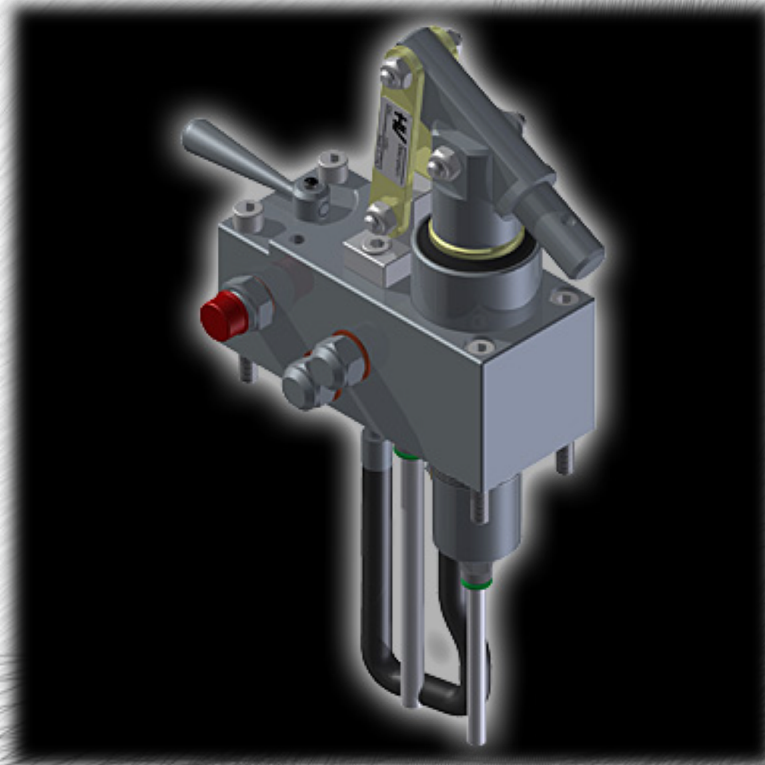

Rev. 0 of 24/09/2019

All rights reserved, including translation. Reproduction in whole or in part of this publication is prohibited without the permission of **HV HYDRAULIC S.r.l.**

Index of the topics covered

1	GENERAL INFORMATION	4
1.1	GENERAL CONSIDERATIONS	4
1.2	CONSULTING THE INSTRUCTIONS	5
1.3	PURPOSE OF THE MANUAL	5
1.4	STORAGE OF THE MANUAL	6
1.5	SYMBOLS OF THE INSTRUCTIONS	6
1.6	REFERENCE LEGISLATION	6
1.7	IDENTIFICATION PLATE	7
1.8	OBLIGATIONS OF THE USER	7
1.9	SELECTION AND QUALIFICATION OF PERSONNEL	7
2	RULES FOR OPERATOR SAFETY	8
2.1	REQUIREMENTS FOR THE SAFETY OF OPERATORS	8
2.3	PERSONAL PROTECTION EQUIPMENT	11
2.4	WORKSTATION	13
2.5	RESIDUAL RISKS	14
3	CHARACTERISTICS	15
3.1	INTRODUCTION	15
3.2	MAIN TECHNICAL CHARACTERISTICS	15
3.3	GENERAL DESCRIPTION OF THE EQUIPMENT	16
3.4	PERMITTED USES OF THE EQUIPMENT	18
4	STORAGE, LIFTING, TRANSPORT	19
4.1	INTRODUCTION	19
4.2	SHIPPING, TRANSPORT, RECEIVING AND UNPACKING THE EQUIPMENT	19
4.3	GENERAL WARNINGS	20
4.4	UNPACKING AND LIFTING OF THE EQUIPMENT	21
5	INSTALLATION	22
5.1	INTRODUCTION	22
5.2	INSTALLATION NOTES	22
5.3	CONNECTION OF THE EQUIPMENT	23
5.4	RE-INSTALLATION	23
6	USE	24
6.1	USE	24
6.2	SERVICE CONDITIONS	24
7	MAINTENANCE AND LUBRICATION	26
7.1	INTRODUCTION	26
7.2	GENERAL NOTES ON SAFETY STANDARDS	26
7.3	GENERAL NOTES FOR MAINTENANCE INTERVENTIONS	27
7.4	GENERAL PROCEDURE AND MAINTENANCE ACTIONS	27
7.5	GENERAL CLEANING	28
7.6	ROUTINE MAINTENANCE	29
8	TROUBLESHOOTING	30
8.1	EXTRAORDINARY MAINTENANCE	30
9	STORAGE, DEMOLITION AND DISPOSAL	31
9.1	STORAGE	31
9.2	DEMOLITION AND DISPOSAL	31
9.3	DISPOSAL OF THE EQUIPMENT	32

9.4	DEMOLITION MATERIALS	32
9.5	INDICATIONS FOR THE CORRECT TREATMENT OF WASTE MATERIALS	32
	TECHNICAL DATA SHEET	33

IMPORTANT!

Before operating the equipment, please read the technical instructions contained in this publication thoroughly and follow the directions provided carefully.

IMPORTANT!

Keep this manual and all the appended publications in a location that is known and accessible to all users (operators and maintenance personnel).



WARNING: for the sake of clarity some images of this manual may show the equipment without guards.



WARNING: for the sake of clarity, some images in this manual may show the equipment not installed in the final place of use.

1 GENERAL INFORMATION

1.1 GENERAL CONSIDERATIONS

The equipment in question consists of a hydraulic pump that allows you to manually operate the movement of the equipment on which it is installed. This equipment is used in many different sectors from agriculture and earth-moving machinery up to industry, the automotive and the wind industry. The equipment is designed to ensure the best results, assuming that all operational instructions and recommendations described in these instructions must be followed; the equipment must not be used for other types of use.

Staff training is important for the maintenance and monitoring compliance with the operating procedures and all the safety rules set out in these instructions.



IMPORTANT!

The equipment must not be used for other types of use other than those indicated in these installation and operation instructions.

IMPORTANT!

For best results, it is recommended that all maintenance operations be performed regularly to keep the equipment in the best condition.

IMPORTANT!

Proper training of the personnel responsible for the equipment is particularly important, both in terms of its installation and its maintenance, control of operational procedures and all the safety rules contained in these operating instructions.



The operating instructions do not replace but supplement the obligations for complying with current safety and accident prevention regulations.

IMPORTANT!

Before operating the equipment, please read the technical instructions contained in this publication thoroughly and follow the directions provided carefully.

IMPORTANT!

Keep these instructions and all the appended publications in a location that is known and accessible to all users (operators and maintenance personnel).



Warning: for the sake of clarity, some images in this manual may show the equipment without some protection devices or not installed in the final place of use.

1.2 CONSULTING THE INSTRUCTIONS

These installation and operation instructions have been organized so that the user can find the information needed to install, use, and maintain the equipment quickly and easily. The user must read the operating instructions in their entirety, with very carefully, and make sure all the information contained is perfectly assimilated. The secondary function of the instructions is to be a reference and consultation document, to be used whenever you need to perform a procedure or operation. Therefore, it should always be kept available to the service and maintenance personnel so that it can be consulted at any time. The consultation of these instructions is facilitated by a table of contents, allowing you to immediately locate the section of the subject that interests you. The index is composed of 9 main chapters numbered, according to the logic [a, b] where "a" indicates the number of the general chapter, "b" the sub-chapter with specific topics. For greater clarity, a number of safety symbols have been inserted alongside certain paragraphs to highlight their importance and make them easier to identify. Pay special attention to these notes.

INTELLECTUAL PROPERTY: We reserve all rights associated with this document and with the object represented therein. The party that receives it acknowledges these rights and undertakes, in the absence of our prior written authorization, not to make it accessible to third parties either entirely or partially and not to use it outside the purpose for which it was assigned.

EXECUTION VARIATIONS: the documentation describes several execution variants, only the indications relative to the specific execution are valid from time to time. If the indications do not make express distinction, they are logically applicable to all the execution variants.

1.3 PURPOSE OF THE MANUAL

This manual is an integral part of the equipment and has the purpose of providing all the information necessary for:

- Correct awareness of operators regarding safety issues;
- The handling of raw materials, products and derivatives, in safe conditions;
- The correct adjustment and commissioning of the equipment;
- The thorough understanding of its operation and limits; its proper use under safe conditions;
- Execute maintenance work correctly and safely;
- The dismantling of the equipment under safe conditions and in accordance with the applicable regulations to protect workers' health and the environment.

1.4 STORAGE OF THE MANUAL

The manual must accompany the entire operating life of the equipment, therefore it must be kept with the utmost care and must be handed over to the new owner in the event of its sale. To ensure its preservation, we recommend storing the original in a safe place, possibly different from that of its normal use. The place of storage must be dry, protected from dust and extreme temperatures and, possibly, from the fire. It is good practice to handle it with clean hands making notes, if necessary, on separate sheets or on the spaces provided in the various volumes.



DOCUMENTATION: These operating instructions and/or spare parts lists are intended for those people in your company who are entrusted with the use and surveillance of machines and installations. It is therefore of the utmost importance that this documentation is actually delivered to those people.



The user can integrate the information provided by **HV HYDRAULIC S.r.l.** with additional work instructions, obviously not in contrast with the information in this manual, to contribute to the safe use of the equipment and its components.



Alterations, corrections, masking or deletion of parts of the text are prohibited.

1.5 SYMBOLS OF THE INSTRUCTIONS

The following symbols will be used in these operating instructions to highlight particularly important indications and warnings:



This symbol indicates the prohibition to perform certain manoeuvres and operations, which may threaten the safety of the operator and the integrity of the equipment. Carefully read the note on the side.



This symbol indicates important fundamental hazard messages for the safety of the operator and the product. Carefully read the note on the side.

IMPORTANT!

This indication intends to highlight a note in the manual particularly important for the use of the equipment.

1.6 REFERENCE LEGISLATION

- **Legislative Decree 81/08:** Health and safety in the workplace.

1.7 IDENTIFICATION PLATE

The identification plate is positioned on the equipment. All equipment identification data are engraved on the plate.



Fig.1.1: Equipment identification plate.



It is absolutely forbidden to remove or tamper with identification plates and pictograms.

1.8 OBLIGATIONS OF THE USER

The user of the equipment must ensure that:

- The equipment is intended only and exclusively for the designated and agreed uses under contract. The operating instructions are freely available for the personnel in charge and which has been properly instructed on the use of the equipment, and is in compliance with all the safety, accident prevention and specification regulations of the equipment itself.
- The goods purchased are not intended for a purpose other than that for which the sale took place and its intended use. They also undertake, in order to protect the trademark, not to make changes to the construction, use and aesthetics of the products purchased.

1.9 SELECTION AND QUALIFICATION OF PERSONNEL

For the work on the equipment, two professional figures have provided: two for production and two for maintenance. Each professional figure has his own field of expertise and the ability to perform certain operations that can be banned to other professional figures.



FIRST LEVEL OPERATOR: An untrained person, who uses the equipment available under instructions from the second-level operator and cannot make adjustments. Hereinafter referred to as Operator.

2 RULES FOR OPERATOR SAFETY

2.1 REQUIREMENTS FOR THE SAFETY OF OPERATORS

The regulations listed below must be read carefully and become a fundamental part of daily practice in the installation and maintenance of the equipment, in order to prevent any kind of injury to persons and/or damage to things.



Do not attempt to use the equipment until you have clearly understood its use and how to install it. If you have any doubts, despite having read these instructions carefully and completely, contact the department manager.



Ensure that all safety requirements are known to the personnel involved in the installation, cleaning, maintenance and use of the equipment.



It is mandatory to keep all the plates with hazard and safety signs in perfect condition. In case of damage or deterioration, they must be promptly replaced.



Before using the equipment, the operator must check for visible defects on the structure and its components. In this case, immediately notify the department manager of the defect encountered.



The operator's clothing must be as suitable as possible, that is to say not excessively large and without loose or flapping parts. Do not wear clothes, jewellery, accessories, which can get caught. Do not wear belts, rings, bracelets or necklaces.



Pay close attention to all the caution, warning and hazard signs placed on the equipment.



Keep the ground in the area surrounding the equipment constantly clean both from clutter and water.



Always wear safety shoes, work clothes, gloves and any other personal protective equipment in areas that require it.



Before starting any work, focus full attention on the task to be performed. You must be extremely careful and always remain vigilant with quick reflexes; these are fundamental conditions for the operator.



Never carry out maintenance or adjustment work alone. Another person should always be present in any case, in order to provide first aid.



Clean the equipment components with soft and dry cloths. It is forbidden to use any type of solvent, such as alcohol or petrol or thinner. For cleaning all surfaces.



It is forbidden to have work performed on the equipment by personnel with a different qualification than the one requested.



Do not use the equipment when under the influence of alcohol, psychopharmacological drugs or drugs.



Never smoke during work or maintenance, especially when solvents or flammable materials are in use.



Do not assume unstable positions to carry out repairs or adjustments; If necessary, use self-propelled bridges or other personal lifting equipment to perform the necessary operations in a safe position.

IMPORTANT!

RECEPTION: A visual inspection must be carried out immediately after the arrival of the equipment. If damages due to transport are found, the necessary steps must be taken according to the supply contract to cover the damage.

IMPORTANT!

ASSEMBLY AND INSTALLATION: The assembly and installation of **HV HYDRAULIC S.r.l.** equipment and their elements must be carried out exclusively by qualified personnel in this regard and in compliance with all the assembly and installation instructions that have been provided.

IMPORTANT!

MAINTENANCE/CLEANING: Maintenance must be carried out only by qualified personnel who have previously studied the requirements of this documentation. These provisions aim to preserve the value, reduce wear and extend the life of machines and installations. Cleaning work must be carried out according to the law and the indications provided in the documentation supplied.

IMPORTANT!

STORAGE: Equipment and instruments, which cannot be stored in their final location, should be stored in their packaging in a sheltered place against weather or other.

IMPORTANT!

OPERATION AND ADJUSTMENTS: Start-up and adjustments must be carried out by specialised personnel. It is essential that before the first use the operating personnel thoroughly study all the warnings contained in the installation and operation manual.

IMPORTANT!

ACCIDENT PROTECTION: This document must be strictly complied with for accident prevention. **HV HYDRAULIC S.r.l.** strives to build its equipment in accordance with the current international safety standard.

2.3 PERSONAL PROTECTION EQUIPMENT

The operator must know the layout and correct operation of the components and the characteristics of the equipment before starting work and must have read the following operating instructions and, if applicable, the attached manuals.

IMPORTANT!

It is the obligation of the employer to provide the Personal Protective Equipment and inform the personnel on the proper use and maintenance.

IMPORTANT!

The operator must always comply with the requirements indicated by the signs shown on the equipment.

IMPORTANT!

It is the worker's obligation to use Personal Protective Equipment necessary to perform safely the lifting, transportation, managing, maintenance and cleaning operations of the equipment.

The PPEs (personal protective equipment) that the operator must use are:

1. During operation:

Work wear, shoes with non-slip sole.

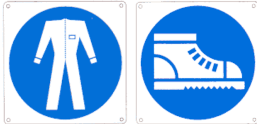

2. During installation, maintenance and cleaning operations:

Work wear, suitable means of protection (aprons, breastplates, leg guards), shoes with non-slip sole, gloves, protective mask or goggles and helmet.



3. During transport operations:

Work wear, shoes with non-slip sole, gloves, helmet.



Prohibition of wearing dangerous clothing and the obligation to wear standard protective clothing, such as to prevent entanglement with moving parts of the equipment and therefore constitute a danger to the safety of the worker;

NOTE: Depending on the type of work performed, it is necessary to use suitable protective gloves for your hands; especially:

- **Gloves made of Kevlar, cotton coated nitrile or PVC, leather where high abrasion resistance is necessary.**
- **Gloves reinforced with wire mesh or equivalent materials where a high shear and impact resistance is necessary.**
- **Gloves against thermal hazards EN407 where high heat resistance is necessary.**
- **Against the risk of contact with energised equipment, it is essential to use insulated gloves, made of rubber latex, on which the maximum tolerable voltage must be written, which can vary from 5000 to 30000 V.**

You must also abide by the following behaviour:

- **Constantly clean the gloves in the manner specified by the manufacturer.**
- **Store the gloves in a suitable place.**
- **Check the integrity of the gloves before use.**

Below is a brief description of the PPE that the operator must use if necessary.

FOOTWEAR (foot protection)



They must have the anatomical anti-stress insole for the comfort of the foot and the upper part must be impenetrable to the contact with the product to be used. They must fully cover the ankle by overlapping with the trousers and must be of the rapid slip-off type to allow quick evacuation of the foot in case of accidental contact with the product. They must also allow the foot to breathe properly.

GLOVES (hand protection)



They must be suitable for the hand of the operator who will wear them and must be long enough to cover the elastic garment on the wrist of the operator. They must ensure a safe and rapid grip as well as ensuring high performance of resistance to the product to be manipulated. They must also ensure protection and comfort against low and high temperatures and good absorption of perspiration.

MASKS (head and eye protection)



They must be of a suitable size for the face of the operator who will have to wear them. They must be double cartridge to offer a more balanced weight arrangement, they must have a large filtration surface to ensure less breathing difficulty, they must have a wide field of vision to ensure good visualisation of the environment and the equipment, they must have a phonic diaphragm to ensure good communication. The sealing system must be adjustable and the sealing edge must be of the "double lip" type to ensure certain impenetrability of the product. The supplied filters, in addition to ensuring the absolute impenetrability of the product, must also be removable and easily reassembled.

HELMETS (head protection)



They must have excellent resistance to both impact and contact with the product itself. The harness must be adjustable. The helmet must be equipped with front sweatband and chinstrap to allow correct fastening. The material with which it is made must be able to withstand both high and low temperatures. It must allow the operator to have excellent comfort in order to ensure that his task is carried out correctly and safely.

CLOTHING



The clothing that the operators must be equipped with must be of resistant material, and they must allow perfect mobility in the movements that the operator must perform. The ends of this clothing must remain close fitting to the body (elastic type) especially the ankles, wrists, neck and stomach, in order to prevent part of fluttering clothing to come into contact with moving parts, thus generating serious dangers. Furthermore, the clothing must ensure the absolute impenetrability of the product.

2.4 WORKSTATION

The equipment in question consists of a hydraulic pump that allows you to manually operate the movement of the equipment on which it is installed. This equipment is used in many different sectors from agriculture and earth-moving machinery up to industry, the automotive and the wind industry. During the normal operating cycle, the constant presence of 1 operator is required because the equipment is operated exclusively by hand. The work phases take place in conditions of safety for the operator.

The following workstations are provided for operating personnel:

1. **AT THE MANUAL DRIVE LEVER OF THE PUMP** for pump drive operations and manual handling of the systems connected to it.
2. **AT THE PUMP CONNECTIONS** for connecting the pump on the tank.

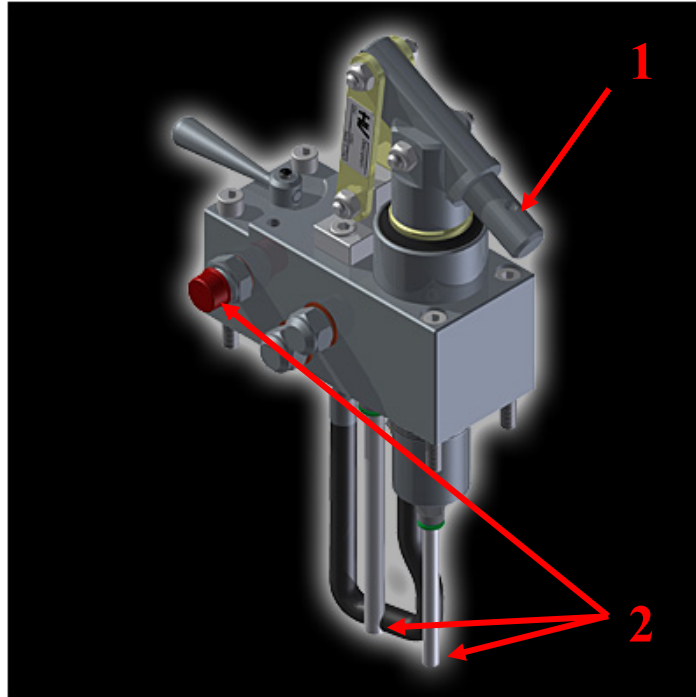

Fig 2.1: Workstation.

IMPORTANT!

For more information on how to use the equipment, see chapter no. 6 "USE".

IMPORTANT!

The equipment is designed and calculated to be used for the intended purposes as indicated in the technical specification by HV Hydraulic. No modification of the equipment is permitted that could compromise its functionality or degree of resistance and therefore the inherent safety.

IMPORTANT!

Any modification made to the equipment is considered as tampering with the equipment and as such criminally prosecuted.



Before using the equipment, the operator must check for any visible defects. In this case, immediately notify the department manager of the defect encountered.

2.5 RESIDUAL RISKS

The equipment has been designed and built with the appropriate measures to ensure the user's safety. However, there are some residual risks linked to the incorrect use of the operator;



**DANGER OF EJECTION OF
LIQUIDS UNDER PRESSURE**



CRUSHING HAZARD

Since the greatest risks occur when an operator intervenes near the dangerous area to install, adjust, clean, maintain the equipment or perform other manual operations that are necessary, these operations must be carried out with the utmost care.

RESIDUAL RISK OF EJECTION OF FLUIDS UNDER PRESSURE

The manual pump is designed to make installation simple and prevent errors being made, but there remains a potential residual risk of ejection of hydraulic fluids under pressure in the event of incorrect installation/connection of the equipment and/or due to incorrect operator manoeuvres.

RESIDUAL RISK OF CRUSHING

The manual pump is designed to make installation simple and prevent errors being made, but there is still a potential residual risk of crushing in the event of incorrect installation of the equipment and/or due to incorrect operator manoeuvres.



It is strictly forbidden to get on and/or climb on the equipment or parts of them to reach the connection areas of the manual pump.

3 CHARACTERISTICS

3.1 INTRODUCTION

The purpose of this chapter is to provide an overview of the characteristics of the equipment. Reading this chapter is recommended for all personnel operating the equipment: OPERATORS and QUALIFIED TECHNICIANS.

3.2 MAIN TECHNICAL CHARACTERISTICS

The single-acting hand pumps for single-acting cylinder are divided into the following models:

PM2V 5-50 D – Assembly on tank - Available displacements: 5-50 cc

Versions

PM2V 5-50 a-d-byB

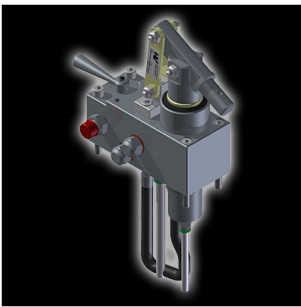

Version with automatic exclusion control 1st stage, with release hand knob and by-pass valve.

Version with 4/3 closed center distributor.

External galvanized details.

Rod/Piston with treated with Niploy.

Tank mounting.

Displacement 5-50 cc.

PM2V 5-50 DVB – Assembly on tank - Available displacements: 5-50 cc

Versions

PM2V 5-50 a-vb-byB

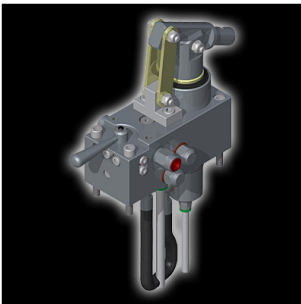

Version with automatic exclusion control 1st stage, with release hand knob and by-pass valve.

Version with 4/3 closed center distributor and block valves.

External galvanized details.

Rod/Piston with treated with Niploy.

Tank mounting.

Displacement 5-50 cc.



For more information on the technical characteristics of the equipment, consult the technical data sheet of the specific model attached to this documentation.

3.3 GENERAL DESCRIPTION OF THE EQUIPMENT

The equipment in question consists of a hydraulic pump that allows you to manually operate the movement of the equipment on which it is installed. This equipment is used in many different sectors from agriculture and earth-moving machinery up to industry, the automotive and the wind industry. The equipment is designed to ensure the best results, assuming that all operational instructions and recommendations described in these instructions must be followed; the equipment must not be used for other types of use.

The various models may differ slightly in conformation and technical characteristics (material, displacement, presence of hand knobs, levers, bypass valves, etc.) as described in the previous paragraph of this Manual

The main groups of equipment are shown below:

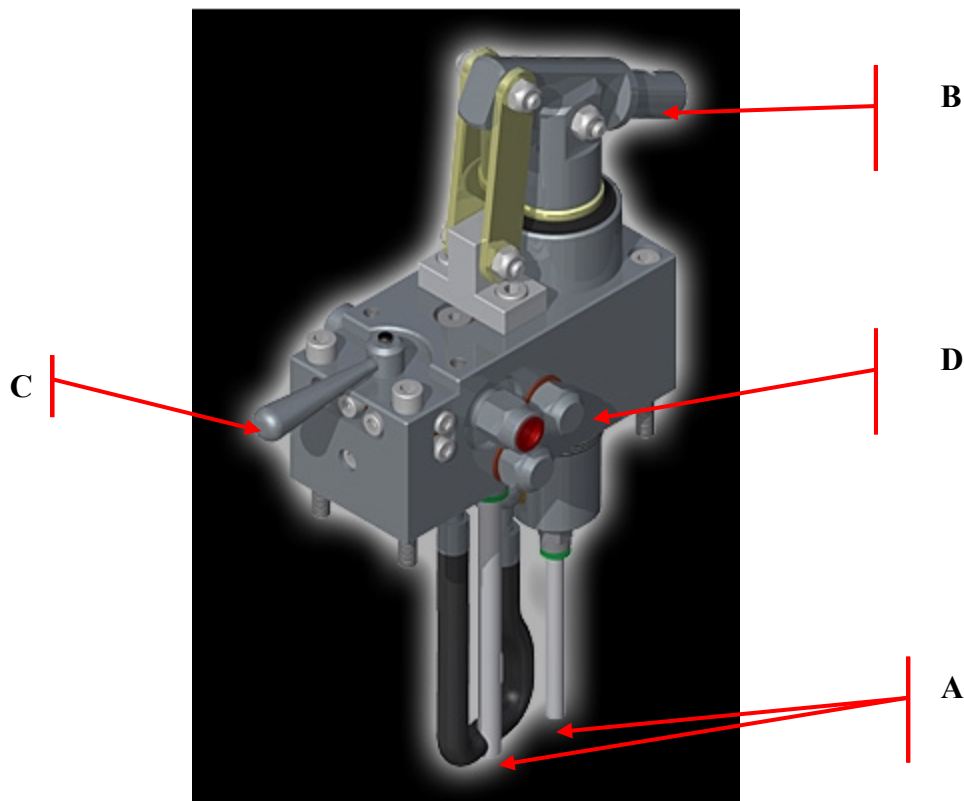

Fig.3.1: Main components of the hand pump



If uncertainties arise about the composition of the equipment, despite having read this manual carefully and completely, consult the drawings; if further doubts persist, contact the department manager.

Key Fig.3.1

- A. **Fluid inlet** → the hand pump can be installed on a tank, therefore, it is supplied with a special gasket kit and screws for assembly on the tank. The tank can be supplied by HV HYDRAULIC s.r.l.

- B. Hand pump drive** → the seat represented in the image allows the insertion of special accessories (Drive levers) that are grafted inside and allow the manual pumping of the oil.
- C. 4/3 closed center distributor** → allows to control the oil flow direction.
- D. Pump cylinder the** → body of the equipment inside which the hydraulic fluid passes.

Below is the meaning of the letter codes that accompany the various models for a clear identification of the technical characteristics.

a: presence of 1st stage automatic exclusion command;

d: presence of 4/3 closed center distributor;

vb: presence of 4/3 closed center distributor and block valves;

byB: presence of bypass valve.

Below are the accessories that can be combined with hand pumps:

Tanks for hand pumps

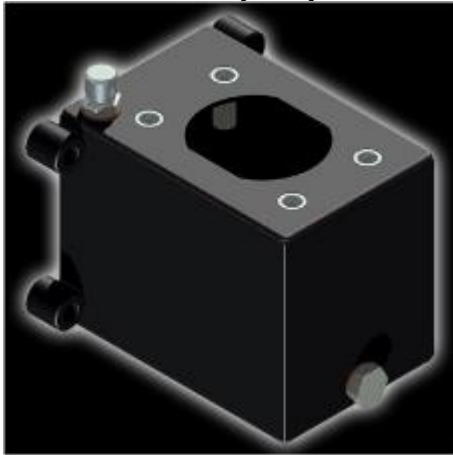

Round section levers for hand pumps



Fig.3.2: Accessories for hand pumps

3.4 PERMITTED USES OF THE EQUIPMENT

The equipment may only be used for the purpose for which it was intended.

The equipment in question consists of a hydraulic pump that allows you to manually operate the movement of the equipment on which it is installed. This equipment is used in many different sectors from agriculture and earth-moving machinery up to industry, the automotive and the wind industry.

IMPORTANT!

The equipment cannot be used differently without the express authorization or any structural modifications by **HV HYDRAULIC S.r.l.**

IMPORTANT!

For damages caused by the use of spare parts from other sources, warranty claims are excluded. Under no circumstances can the manufacturer be charged damages due to inadequate treatment, non-compliance with our requirements, operating errors by untrained personnel.

IMPORTANT!

Tampering, unauthorized replacement of one or more parts of the equipment, unauthorized maintenance, the use of accessories, tools, spare parts, consumables and production other than those recommended by **HV HYDRAULIC S.r.l.** may represent a hazard to the safety of the operator and the equipment itself and relieve the manufacturer from civil and criminal liability.



The use of the equipment is allowed only to qualified personnel, namely: **TRAINED TECHNICIAN** of the Customer properly trained and experienced in the installation, use and maintenance of the Customer's systems and is aware of the regulations on accident prevention.

4 STORAGE, LIFTING, TRANSPORT

4.1 INTRODUCTION

The purpose of the following chapter is to provide information for lifting and transporting the equipment. The information in this chapter is intended for the **QUALIFIED TECHNICIAN** with adequate knowledge to operate in a suitable manner and in conditions of safety in the use of forklifts and whatever else is necessary.



LIFTING AND TRANSPORT OPERATIONS MAY IMPLEMENT A RESIDUAL RISK IN THE EVENT OF FALL OF THE EQUIPMENT BEING HANDLED.

IMPORTANT!

It is the worker's obligation to use Personal Protective Equipment necessary to perform the lifting and transportation procedures of the equipment in complete safety.

4.2 SHIPPING, TRANSPORT, RECEIVING AND UNPACKING THE EQUIPMENT

IMPORTANT!

Upon receipt of the equipment, check that it is intact in all its parts. If there are damaged parts, immediately inform **HV HYDRAULIC S.r.l.**

Upon arrival of the equipment, at the customer's plant, the following must already be prepared:

- sufficient space for installation;
- the most suitable means for unloading and positioning the components on-site.



All reception and unloading operations must take place in the presence of a single manager, who is responsible for monitoring the operations, the lack of essential parts for the perfect assembly of the equipment and their damage during transport (with the help of the transport document).

IMPORTANT!

At the end of the transport and installation operations, the packaging must be disposed of according to the laws in the country of installation of the equipment. Disposal of packaging material is the responsibility of the end customer.

Upon receipt of the equipment, check with the carrier that the package is intact, that it has not suffered any damage during transport or has been opened voluntarily to subtract parts inside. Check that the supply corresponds to the specifications of the purchase order and check with the transport documents that the delivery is complete. If the packaging is damaged externally, open them in the presence of the carrier and check that the equipment has not been damaged.

Depending on the method of transport used and the type of products to be shipped, **HV HYDRAULIC S.r.l.** uses appropriate packaging to ensure integrity and preservation during transport.

4.3 GENERAL WARNINGS



All personnel must be aware of the accident prevention regulations.



IT IS NECESSARY TO CONSIDER THE WEIGHT OF THE LOAD LIFTED!!! Check that load stability cannot be the cause of hazards and/or accidents. In the event of handling of packages whose dimensions do not allow sufficient visibility, the assistance of a ground operator is required.



Make sure that the vehicles and logistic structures used comply with the use and are in perfect operating condition.



Keep away from suspended loads, ensure that ropes and lifting straps are in perfect condition and properly inserted into the relevant hooks, the latter must be equipped with safety lever.



During handling operations, operators must be equipped with the appropriate personal protection equipment, such as gloves, shoes with a non-slip sole and work helmet.



To prevent certain parts from hitting people in the event of equipment or parts falling, make sure that during lifting operations, there are no persons within the range of the lifting machines.



In case of use of lifting equipment with the relevant tools (ropes, hooks, chains, eye bolts, shackles etc.) always make sure that they are suitable for lifting the load to be handled and check the necessary stability of the latter.



Handling is forbidden on unpaved or uneven or heavily uneven ground.



Hazards due to suspended loads



No standing under loads



Before starting the handling, check the stability of the components to be transported.

4.4 UNPACKING AND LIFTING OF THE EQUIPMENT

As indicated in the chapter on the "CHARACTERISTICS", the equipment has reduced dimensions and weight that can be moved manually.

In order to ensure the safe handling of the equipment, strictly follow the general guidelines below:

- a. Transport the equipment still packed as closely as possible to the place of installation, then unpack it making sure to check that the contents correspond to the transport document.
- b. Remove the cover remove all disassembled components and accessories. Carefully release all the material used for packing the equipment components.

IMPORTANT!

Handling must be done carefully to avoid damage to parts of the equipment.

IMPORTANT!

Under no circumstances can the manufacturer be charged damages due to inadequate treatment, non-compliance with our requirements, operating errors by untrained personnel.

5 INSTALLATION

5.1 INTRODUCTION

The purpose of the following chapter is to provide the information for the safe installation of the equipment. The information in this chapter is intended for the **QUALIFIED TECHNICIAN** with adequate knowledge to operate in a suitable manner and in conditions of safety during installation operations. All personnel must be aware of the accident prevention regulations.

IMPORTANT!

It is the worker's obligation to use Personal Protective Equipment necessary to perform the installation procedures of the equipment in complete safety.

5.2 INSTALLATION NOTES



All the technical characteristics of the equipment necessary for the correct installation are given in this chapter and in the chapter on "CHARACTERISTICS".

Before starting installation the following conditions must be met:

- Make sure the equipment is perfectly clean;
- Check that there are no objects scattered near the workstations;
- Check that the surface is sufficiently flat and does not have any hollows and/or bumps;
- Check that, when the equipment is in position, the minimum space from walls, pillars or other is such that there is no impediment to the use and maintenance of the equipment;
- Make sure to clear the area where the equipment will be installed in advance.

5.3 CONNECTION OF THE EQUIPMENT

The hand pump is designed to be installed on a tank, which can be supplied as an HV Hydraulic accessory or prepared by the customer. The hand pumps for tank assembly are supplied with gasket kit and 4 screws for assembly.

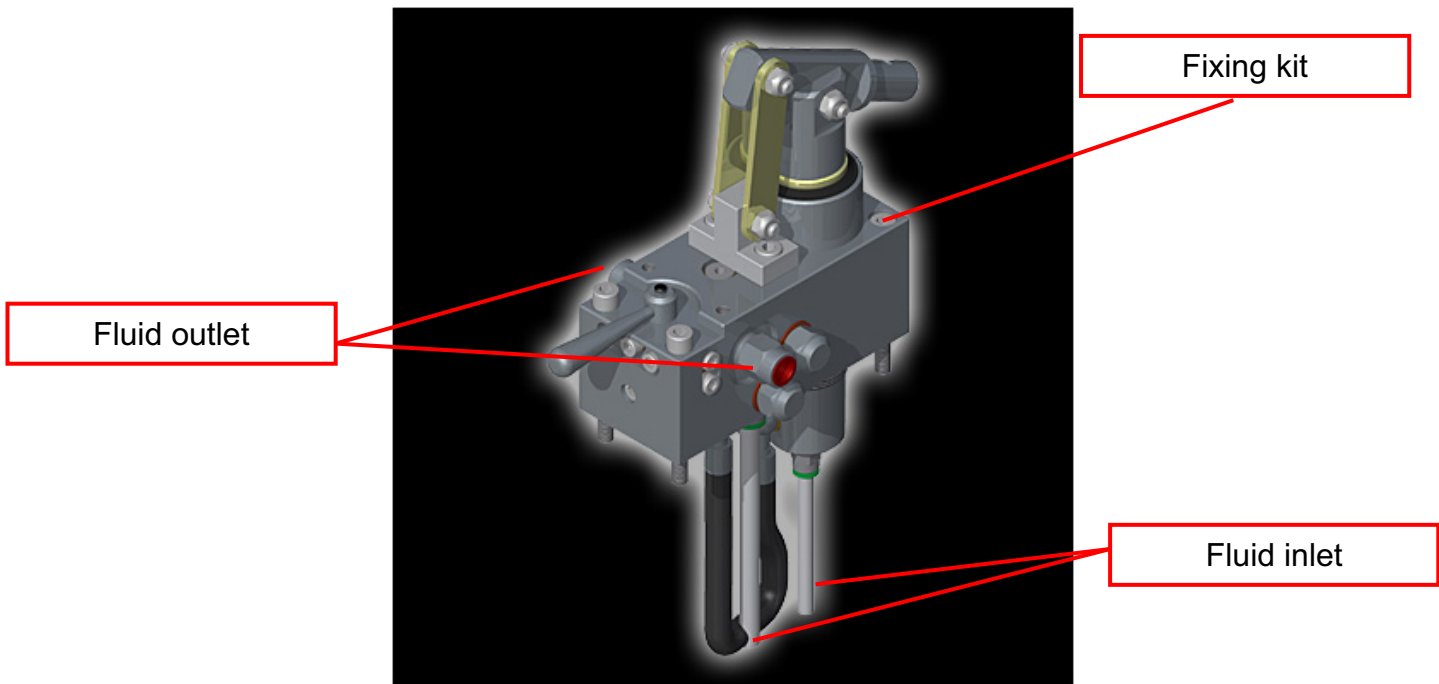

Fig.5.1: Hand pump - installation on tank



Check for corrosion/marks/deformations/cracks on the equipment before using it.



The first installation and adjustment of the equipment must be carried out exclusively by suitably trained personnel. All the technical characteristics of the equipment necessary for the correct installation are given in this chapter and on the technical data sheet of the selected product attached.

5.4 RE-INSTALLATION

The activities described in this paragraph must only be performed by qualified personnel: a trained technician who has attended specialization and training courses and has experience in the installation, use and maintenance of the equipment, and is aware of the regulations on accident prevention. To uninstall the equipment in case of sale, re-installation or external storage, follow this general disassembly procedure:

1. Remove the process hydraulic fluids and disconnect the relative pipes;
2. Mechanically disassemble the equipment by dividing it into the established parts;
3. Block using mechanical locks, fasteners or by tying all the parts that can move or slide during transport.

IMPORTANT!

For lifting, transporting, re-positioning and connection, refer to the relevant paragraphs of this manual.

6 USE

6.1 USE

When the equipment is used for the first time, all the movements must be checked, allowing the EQUIPMENT to perform ALL POSSIBLE MOVEMENTS.



Check for corrosion/marks/deformations/cracks on the equipment before using it.

After checking the equipment, the operator performs the following actions:

- Installation of equipment in-line or on tank as described in the previous paragraph of this Manual;
- Check for air in the system and purge if necessary. To purge, loosen the delivery connection and perform manual pumping to complete the expulsion of the air inside the circuit;
- Use the hand pump according to the need to operate the mechanisms on which it is installed. To carry out manual pumping, it is necessary to insert a special operating lever (which can be provided as an original HV Hydraulic accessory) in the appropriate seat and operate the movements by hand. The two-stage hand pumps allow to adjust the feed speed thanks to the presence of two pumping organs that allow to pass from a low pressure condition to a high fluid pressure condition and are suitable for **connection to the double-acting cylinder which has two chambers in which the pressurized fluid can be alternately acted upon, so as to exploit the thrust of the fluid both during the working stroke and during repositioning.**
- For models equipped with hand knobs or levers, it is possible to act on these elements to obtain the desired effect (fluid discharge and/or deviations, selection of the operating stage).



Attention: the use of the equipment is reserved for personnel suitably trained on the use of the system where it is installed.

6.2 SERVICE CONDITIONS

Use only mineral-based hydraulic oil according to ISO 6743/4 (DIN 51524) with viscosity according to ISO 3448 (DIN 51519) parameters. The degree of viscosity is indicated by the letters ISO VG followed by a number indicating the average kinematic viscosity at 40°C in mm²/s or centistokes (cSt).

Minimum allowed viscosity: 15 mm²/s

Maximum allowed viscosity: 100 mm²/s

Recommended viscosity: 46 mm²/s

Degrees of viscosity	Average kinematic viscosity mm ² /s at 40°C	Limit of kinematic viscosity mm ² /s at 40°C	
		Min.	Max.
ISO VG 15	15	13.5	16.5
ISO VG 22	22	19.8	24.2
ISO VG 32	32	28.8	35.2
ISO VG 46	46	41.4	50.6
ISO VG 68	68	61.2	74.8
ISO VG 100	100	90.0	100.0

Tab.6.1: Table of permitted viscosity grades



Attention: excessive contamination of the fluid is the main cause of malfunction in hydraulic systems. 15-micron filtration is recommended - Class of contamination 18/14 ISO 4406 (9 NAS 1638).



Use the equipment at an ambient temperature between - 20°C and + 50°C and with oil at a temperature between - 20°C and + 80°C.

7 MAINTENANCE AND LUBRICATION

7.1 INTRODUCTION

This chapter is addressed to the **MAINTENANCE TECHNICIAN**.



The activities described in this paragraph must **ONLY BE PERFORMED** by qualified personnel, and precisely: **TRAINED TECHNICIAN WHO HAS FOLLOWED** the specialization and training courses and has experience in installation, use and maintenance of the equipment and is aware of the regulations on accident prevention.

IMPORTANT!

Maintenance technicians must respect the limits of their competences within their competences, comply with the procedures set out in the operating instructions and the warnings associated with them; respect the time and frequency indicated for scheduled maintenance operations.

7.2 GENERAL NOTES ON SAFETY STANDARDS



Maintenance and repair operations must be carried out with access to the equipment and the area which is generally prohibited.



Before intervening on the equipment, position the sign "Maintenance in progress" in the vicinity of it; the area subject to maintenance must be cordoned off, to prevent access by strangers and provided with signs: "danger: maintenance in progress".



Once the maintenance work has been carried out and before putting the equipment back into service, it is always necessary:

- check that any replaced parts and/or equipment used for the maintenance intervention have been removed.
- that any parts that may have been disassembled during the procedure are reassembled correctly and working.



Tampering, removal and modification of protection/safety devices of the equipment **IS STRICTLY PROHIBITED**. In such cases, the manufacturer declines every responsibility for the safety of the equipment.



Only use original spare parts and suitable tools in good condition for the specific task.

The new components that replace the faulty ones must have the same technical characteristics and the same performance; if they are safety components they must be certified and belong to the same class as the original that is replaced. The adjustment of the replaced components must be done adopting the same values already used in the regulation of the replaced component.

IMPORTANT!

The safety and durability of the equipment depends, in addition to other factors, also on the regularity of maintenance.

IMPORTANT!

Given the diversity of operating conditions, it is not possible to determine the exact frequency of wear monitoring, maintenance and revision for all cases.

7.3 GENERAL NOTES FOR MAINTENANCE INTERVENTIONS

NATURE AND FREQUENCY OF MAINTENANCE VERIFICATIONS AND INTERVENTIONS

The systematic verification of some of the most stressed and wear-prone equipment parts can avoid future inconveniences and help to keep the equipment at the highest level of efficiency by ensuring constant operation over time.

MAINTENANCE

A set of organized operations that must be carried out on the equipment parts in a periodic and systematic manner. Ordinary maintenance is divided into:

- a Verification of the state of the various parts.
- b Elimination or correction of anomalies, even those that, while not constituting immediate cause of danger or technical disservice, can lead to inconveniences as a result of their persistence.

EXTRAORDINARY MAINTENANCE

It consists of the complete replacement of parts or organs of equipment that have reached their average life, in order to prevent breakages that cause equipment and production shutdowns. Only after continuous maintenance service and its critical analysis, it is possible to determine the real needs in accordance with the main needs of the company.

7.4 GENERAL PROCEDURE AND MAINTENANCE ACTIONS

Before undertaking a maintenance action, it is necessary to apply the following general procedure:

- a Position the various moving parts of the equipment in the most convenient condition for the maintenance to be performed;
- b Carry out maintenance or repair operations in accordance with the specifications in the respective description of this manual;
- c Once all the operations have been completed, make sure, before using the equipment, that:
 1. All the tools used have been put away;
 2. All people have left the danger zones;
- d Check that the equipment is functioning correctly before using it.



Respect the intervention sequences indicated in the manual. The distance (indicated in time or in work cycles) between one intervention and the other is to be understood as maximum and not to be exceeded. If necessary it can be shortened



Good preventive maintenance requires constant attention and continuous monitoring of the equipment. In case of doubt, contact [HV HYDRAULIC S.r.l.](#)

7.5 GENERAL CLEANING

The equipment may be cleaned by personnel without specific technical expertise, who know the main characteristics of the equipment in order not to run into dangerous situations. Equipment maintenance must be carried out by highly specialized personnel with in-depth knowledge of the same.



Always carry out cleaning operations with the appropriate personal protective equipment (gloves, overalls, non-slip shoes).



Prolonged contact of oils or lubricants with the skin can cause irritation. Strictly observe the rules of personal and work hygiene.

GENERAL CLEANING OF THE EQUIPMENT:



Do not use water or steam jets.

Clean equipment covers with soft dry cloths;

- Remove dust and other dirt from the equipment;
- Accurate daily cleaning from dust is the first condition to keep the equipment efficient;
- Keep the work area clean from any material that might hinder the operations of the workers.

7.6 ROUTINE MAINTENANCE

It must be performed before the equipment is put into service, after each prolonged stop and at least twice a year.



WARNING: this chapter is intended exclusively for the **QUALIFIED TECHNICIAN (MAINTENANCE TECHNICIAN)**.



Prolonged contact of lubricating oils with the skin can cause irritation. Strictly observe the rules of personal and work hygiene.

IMPORTANT!

It is the worker's obligation to use Personal Protective Equipment necessary to perform safely the maintenance and cleaning operations of the equipment.



Prolonged contact of grease with the skin can cause irritation. Strictly observe the rules of personal and work hygiene.



Please note that before performing any maintenance on the equipment or parts of it is necessary:

- In case of equipment failure, apply a warning sign to the same as the one shown at the side;
- Work on the equipment in the rest position;
- Pay attention to the control instruments; replace them when they are damaged;
- Perform all maintenance or repair operations under the responsibility of a single person designated by the employer.

ROUTINE MAINTENANCE INSPECTIONS

Daily check, through a visual inspection, the general wear condition of the equipment; this inspection must take place to prevent any breakages or malfunctions due to the conditions of use in relation to the environment, for example use in an environment invaded by steam, or, in the presence of particularly hot climates, etc. The frequency indicated refers to normal conditions of use; in particularly severe conditions, different frequency is required.

Mandatory inspections:

Inspect:

- the oxidation state of the equipment body and the possible presence of rust and the general conservation status of the equipment;
- the presence of oil leaks, if there are any, proceed with the replacement of the equipment O-rings (contact [HV HYDRAULIC S.r.l.](#)).

8 TROUBLESHOOTING

8.1 EXTRAORDINARY MAINTENANCE

This chapter presents a guide to solving the problems that arise during the use of the equipment; it for the attention of the **QUALIFIED TECHNICIAN**.



WARNING: For any extraordinary maintenance operation, contact the department manager.



Prolonged contact of grease with the skin can cause irritation. Strictly observe the rules of personal and work hygiene.



WARNING: This chapter is intended exclusively for the **QUALIFIED TECHNICIAN (MAINTENANCE TECHNICIAN)**.

Ordinary maintenance operations are contemplated in the previous chapter; in the event that problems arise, please:



IMMEDIATELY CONTACT [HV HYDRAULIC S.r.l.](#)

The main drawbacks that the equipment can present are:

1. The breaking or excessive wear of some of its parts:

In this case, it is necessary to proceed with the order of the component to be replaced by contacting [HV HYDRAULIC S.r.l.](#)

9 STORAGE, DEMOLITION AND DISPOSAL

9.1 STORAGE

In case of prolonged storage, keep the equipment protected from rain and wind, and possibly in a dry place.



It is forbidden to place the equipment on structures that have not been made specifically. It is forbidden to deposit material or instruments on the equipment or parts of it.



In the event of prolonged storage, store the equipment in a place protected against bad weather. If this is not possible, cover the elements well to protect them from intense solar radiation and humidity.



Equipment and instruments that cannot be immediately placed in their final location, are to be stored in their original packaging in a sheltered place against weather or other. The equipment must be placed in an environment sheltered from the rain.

9.2 DEMOLITION AND DISPOSAL



Dismantling the equipment can conceal hazards that are not immediately identifiable, so you must pay utmost attention and caution when performing the necessary operations. It is advisable to entrust the operations to specialized personnel trained by the manufacturer or, alternatively, specifically trained personnel.

At the end of the life cycle of the equipment, the user company must proceed with the disposal of the equipment. After having dismantled the equipment, it is necessary to separate the various materials in accordance with the regulations of the country where the equipment must be eliminated. The equipment does not contain components or hazardous substances that require special removal procedures.

To dismantle the equipment, proceed according to the following general disassembly procedure:

- **Disconnect the body and mechanical parts.**
Recovery of all metal parts making up the structure of the equipment.
All ferrous material must be sent for scrap to the authorised scrapyards.
- **Disconnect the plastic parts.**
Recovery of plastic material. *For plastic materials, delivery is required to authorised centres for the separate collection of industrial waste.*



THE EQUIPMENT MUST NOT BE ABANDONED INTO THE ENVIRONMENT.



WARNING: When handling waste it is necessary to have appropriate personal protective equipment.

9.3 DISPOSAL OF THE EQUIPMENT

Any waste material resulting from the demolition of the equipment must be disposed of in an environmentally friendly way, so as to avoid polluting soil, air and water. In any case, the local legislation in force on the subject must be respected. It should be remembered that waste material is defined as any substance or object the holder disposes of or decides to dispose of or is required to dispose of (Legislative Decree 152/2006). Waste resulting from the demolition of the equipment may be classified as special waste.

9.4 DEMOLITION MATERIALS

The following materials are classified as special, recoverable non-hazardous waste, in accordance with Legislative Decree 152/2006. For the elimination, it should be borne in mind that the materials of which the equipment is made are not hazardous.

WARNING During the disposal process it will be necessary to comply with the regulations in force in the country. Store polluting materials such as oils and solvents only in metal drums.

Consumer products: Regarding the disposal of consumer products, observe the following rules:

Oils: Exhausted oils, oily residues and oil-soaked objects must be disposed of through the appropriate collection points, and not dumped in urban channels.

9.5 INDICATIONS FOR THE CORRECT TREATMENT OF WASTE MATERIALS

The correct management of special waste includes: storage in suitable places avoiding the mixing of hazardous waste with non-hazardous waste; making sure that the transport and disposal/recovery of the same is carried out by authorized carriers and recipients.

Waste may only be transported to authorized collection centres by transport companies who are registered with the appropriate environmental certification body.

TECHNICAL DATA SHEET